

# EMERAL TECH

**24Vin 5Vout 125 Watts**

## Technical Specification

**E24C5M125B**

**High Efficiency Power Converter**

**125 Watts**



## Description

The E24C5M125B Series quarter brick DC/DC converters are comparable to existing quarter-bricks. The E150 family of high efficiency DC/DC converters offer current levels that exceed all other military half-bricks. They are targeted specifically at the aerospace, aircraft portable weaponry industry, distributed power markets and electric vehicles. With a wide input voltage range of 18-36VDC, output 5 VDC. Output power 125W. The model features input undervoltage lockout, output overvoltage protection, overtemperature protection, output overload protection and programmable current limiting, single bus current share and N+1 redundancy. The fully enclosed, encapsulated construction with aluminum heat spreader design achieves efficient heat transfer with no hot spots. The use of patent-pending hybrid planar transformer technology and other patent-pending design concepts facilitate maximum power delivery with the highest efficiency up to 93%. The converters combine creative design concepts with highly derated power devices to achieve very high reliability, high performance and low cost solution to systems designers requiring maximum power in small footprints.

## Applications

- Aerospace, Aircraft
- Complex power system
- Portable weaponry
- Distributed Power Architecture
- Electric vehicles

Show actual size:

2.28 x 1.45 x 0.5 in

57.9 x 36.8 x 12.7 mm

## Features

- DC input range: 16-36V
- Input surge withstand: 50V < 100ms
- Ripple & Noise (20Mhz BW) 300 mv (pk-pk) typical
- DC output: 5V
- Programmable output: 10 to 110%
- Output adjustment +/-10% range
- Regulation: +/- 0.2% no load to full load
- Remote sense compensation
- 1500V, 10M $\Omega$  input-to-output isolation
- Output overcurrent and overvoltage protection
- Over Temperature protection
- Input Under voltage protection
- Parallelable, with N+M fault tolerance
- Power density: 100W/Cubic inch
- Parallelable, with N+M fault tolerance
- Efficiency: 93%

**EMERAL TECH.** No.A-3, Xiuzhou High-Tech Industrial Park, Jiaying City, ZJ 314001 China.

Tel.: 86-573-2790696 • Fax: 86-573-2790698 • www.emeraltech.com • Email: [sales@emeraltech.com](mailto:sales@emeraltech.com) • E250

Part Number and Selection Information

Model Part Number	Input			Output		Efficiency 75% Load (%)
	Voltage (Volts)	Current (A)		Voltage (Volts)	Current (Amps)	
	Nominal	No load	Full load	(Volts)	(Amps)	
<b>E24C5M125B</b>	24	0.030	0.962	5	25	93

Consult factory for other output voltage configurations

Outline Information and Pin-out

Pin Connection		Pin Size	
Pin #	Function	Inch	mm
1	Vin +	0.08"	2.03
2	PC	0.08"	2.03
3	PR	0.08"	2.03
4	Vin -	0.08"	2.03
5	Vo -	0.08"	2.03
6	SC	0.08"	2.03
7	Vo +	0.08"	2.03

All dimensions are in inches [mm]

0.08" [2.032mm]

Pin material: Brass

Pin finish: Tin/Lead plated

Baseplate material: Aluminum.

Outline dimension:

2.28" (57.9)x1.45(36.8)x0.5" (12.7)

Max. Weight: 66g

\* Part Numbering:

**E 24 C 5 M 100 B**

24	C	5	M	125	B
Input Voltage	A=Maxi B=Mni C=Micro	Output Voltage	*	Output Power	Pin Style

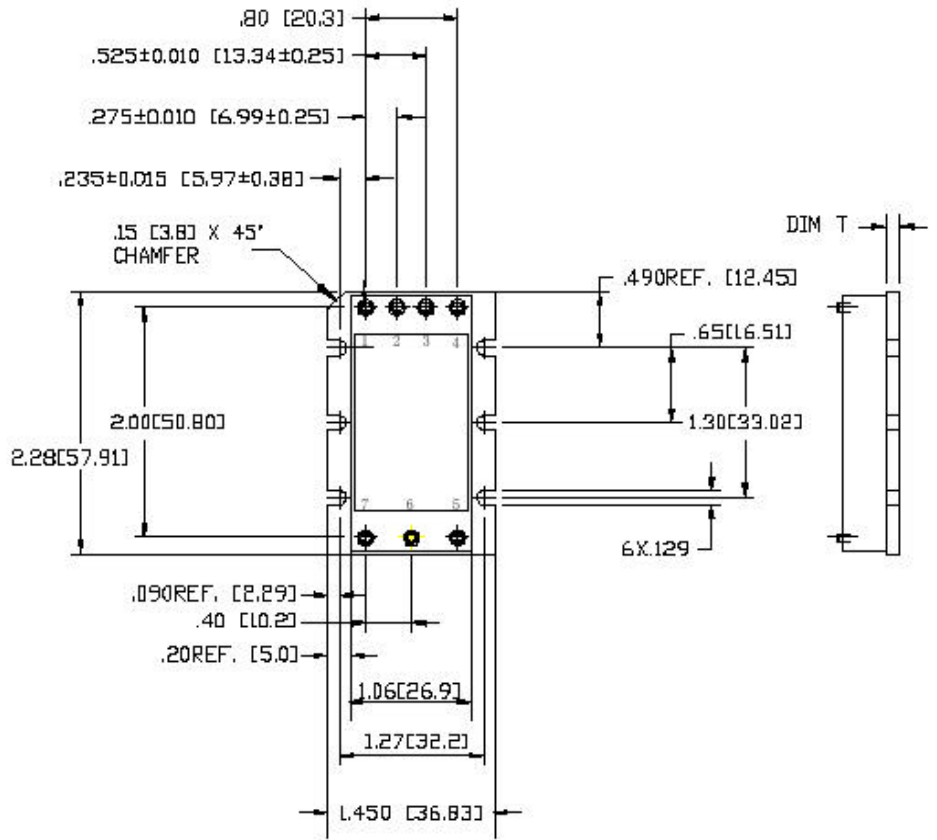

\* Product Grade Temperatures (\* C)

Grade	Storage	Operating
C	= -40 to +125	-20 to +100
T	= -40 to +125	-40 to +100
H	= -55 to +125	-40 to +100
M	= -65 to +125	-55 to +100

## Electrical Specification

Typical operating condition at Ta=25°C, Vin=24V unless otherwise noted.

PARAMETER	NOTES	MIN	TYP	MAX	UNIT
<b>Absolute maximum rating</b>					
Vin+ to Vin- voltage		-0.5		+36	Vdc
Vin+ to Vin- voltage	<100ms		50		Vdc
PC to -In voltage		-0.5		+7.0	Vdc
PR to -In voltage		-0.5		+7.0	Vdc
+Out to -Out voltage		-0.5		+7	Vdc
+Sense to -Out voltage		-0.5		+1.5	Vdc
-Sense to -Out voltage					Vdc
SC to -Out Voltage			-0.5 to +1.5		Vdc
Isolation voltage (in to out)			3000		Vrms
Isolation voltage (in to base)			1550		Vrms
Isolation voltage (out to base)			500		Vrms
Operating case temperature (M - Grade)		-55		100	°C
Storage temperature (M - Grade)		-65		125	°C
Pin soldering temperature			500 (260)		
Ping soldering temperature			750 (390)		
<b>Thermal Resistance and Capacity</b>					
Baseplate to sink; flat' greased surface			0.24		°C / Watt
Baseplate to sink; thermal pad			0.21		°C / Watt
Baseplate to ambient			10.9		°C / Watt
Baseplate to ambient; 1000 LFM			2.8		°C / Watt
Thermal capacity			48		Watt-sec/°C
<b>Module Operating Specifications</b>					
Operating input voltage		18	24	36	Vdc
Input surge withstand	<100ms			50	Vdc
Output voltage setpoint	Nominal input; full load; 25 °C	4.950	5	5.050	Vdc
Output OVP setpoint	25 °C; recycle input voltage to restart (1 minute off)	6.07	6.3	5.53	Vdc
Output power	At 100°C baseplate temperature			125	Watts
Efficiency	Nominal input; 75% of full load; 25 °C	91	92		%
<b>Module Input Specification</b>					
Undervoltage turn-on			17.5	17.9	Vdc
Undervoltage turn-off		14.77	15.3		Vdc
Overvoltage turn-off/on		36.3	37.8	39.6	Vdc
Dissipation, standby	No load		5.1	5.5	Watts
<b>Module Output Specifications</b>					
Line regulation	Low line to high line; full load		+/-0.02	+/-0.2	%
Load regulation	No load to full load; nominal input		+/-0.05	+/-0.2	%
Temperature regulation	Over operating temperature range		+/-0.002	+/-0.005	% °C
Ripple and noise; p-p	Nominal input; full load; 25°C; 20MHz bandwidth		120	160	mV
Current limit	Output voltage 95% of nominal	20.4	23	27	Amps
Short circuit current	Output voltage <250mV	2	23	27	Amps
Power sharing accuracy	10 to 100% of full load		+/-2	+/- 5	%
Programming range	Of nominal output voltage. For trimming below 90% of nominal, a minimum load of 10% of maximum rate power may be required.	10		110	%

Module General Specifications					
Remote sense (total drop)	0.25V per leg (senses must be closed)			0.5	Vdc
Isolation voltage (in to out)	Complies with reinforced insulation Requirements	3000			Vrms
Isolation voltage (in to base)	Complies with basic insulation requirements	1550			Vrms
Isolation voltage (out to base)	Complies with operational insulation requirements	500			Vrms
Isolation voltage (in to out)			10		megohms
Weight		2.1 (60)	2.3(66)		ounces (grams)
Temperature		110	115		°C

### CONTROL FUNCTIONS – PC PIN

#### Module Enable/Disable

The module may be disabled by pulling PC below 2.3V with respect to the – Input. This may be done with an open collector transistor, relay, or optocoupler. Multiple converters may be disabled with a single transistor or relay either directly or via “OR’ing” diodes See Figure 1.

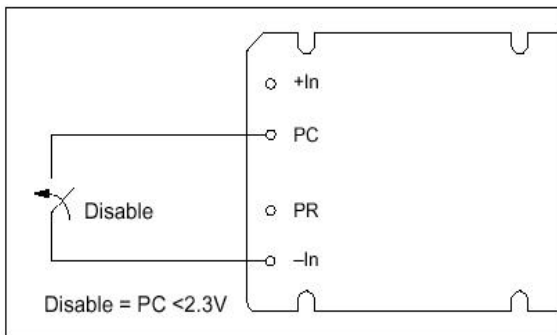

Figure 1—Module enable/disable.

### CONTROL FUNCTIONS – SC PIN

#### Output voltage Programming

The output voltage of the converter can be adjusted or programmed via fixed resistors, potentiometers or voltage DACs. See Figures 2 and 3.

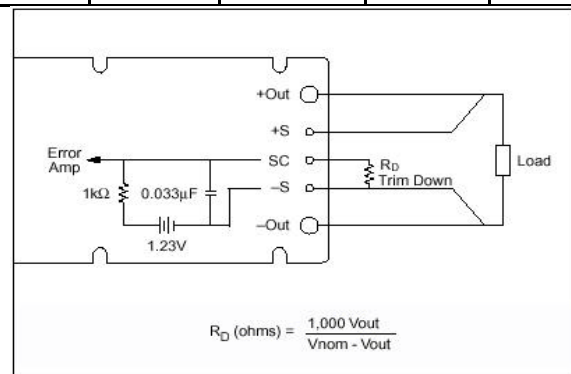

Figure 2 – Output voltage trim down circuit

#### Trim Down

1. This converter is not a constant power device – it has a constant current limit. Hence, available output power is reduced by the same percentage that output voltage is trimmed down. Do not exceed maximum rated output current.
2. The trim down resistor must be connected to the – Sense pin.

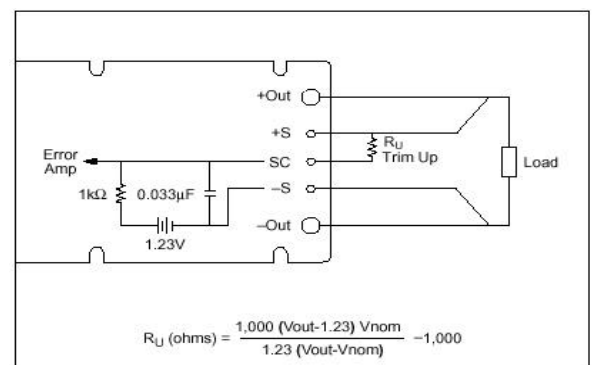

Figure 3 – Output voltage trim up circuit

**Trim Up**

1. The converter is rated for maximum delivered power. To ensure that maximum rated power is not exceeded, reduce maximum output current by the same percentage increase in output voltage.
2. The trim up resistor must be connected to the +Sense pin.
3. Do not trim the converter above maximum trim range (typically +10%) or the output over voltage protection circuitry may be activated.

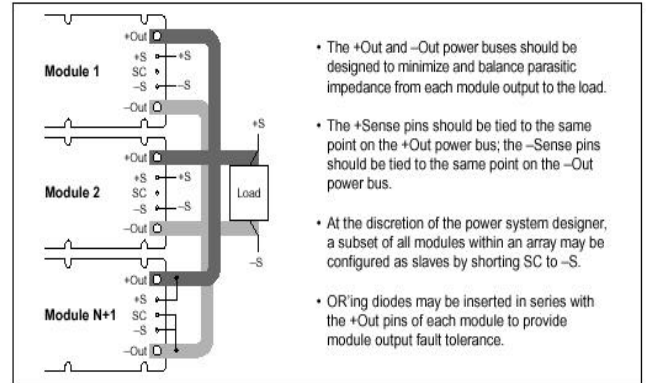

Figure 5 – N+1 module array output connections.

**CONTROL FUNCTIONS – PR PIN**

**Parallel Operation**

The PR pin supports paralleling for increased power with N+1 (N+M) redundancy and phased array capability. Modules of the same input voltage, output voltage, and power level will current share if all PR pins are suitably interfaced.

Compatible interface architectures include the following:  
 DC coupled single-wire interface. All PR pins are directly connected to one another. This interface supports current sharing but is not fault tolerant. Minus In pins must be tied to the same electric potential. See Figure 4.

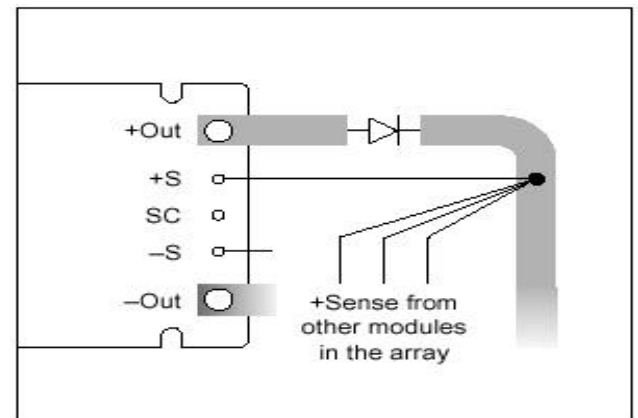

Figure 6 – OR'ing diodes connections.

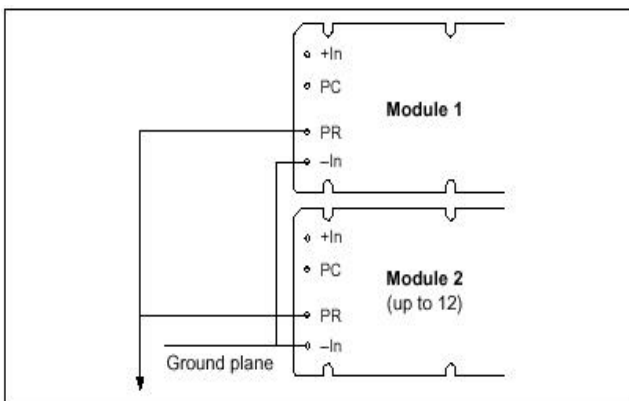

Figure 4 – DC coupled single – wire interface.

**Pin Styles**

Designator	Description	Notes
(None)	Short solder	Requires in-board, mounting
L	Long solder	On-Board mounting for 0.065" boards
S	Short ModulMate	SurfMate or in-board socket mounting
N	Long ModuMate	On-board socket mounting

Pin Style designator follow the “B” after the output power and precedes the baseplate designator.

Ex. E48B24C250BN – Long ModuMate Pins