

EMERALD TECH

150Vin 15Vout 250 Watts

Technical Specification

E150B15M250B

High Efficiency Power Converter

250 Watts



Description

The E150B15M250B Series half brick DC/DC converters are comparable to existing quarter-bricks. The E250 family of high efficiency DC/DC converters offer current levels that exceed all other military half-bricks. They are targeted specifically at the aerospace, aircraft portable weaponry industry, distributed power markets and electric vehicles. With a wide input voltage range of 100-200VDC, output 15 VDC. Output power 250W. The model features input undervoltage lockout, output overvoltage protection, overtemperature protection, output overload protection and programmable current limiting, single bus current share and N+1 redundancy. The fully enclosed, encapsulated construction with aluminum heat spreader design achieves efficient heat transfer with no hot spots. The use of patent-pending hybrid planar transformer technology and other patent-pending design concepts facilitate maximum power delivery with the highest efficiency up to 93%. The converters combine creative design concepts with highly derated power devices to achieve very high reliability, high performance and low cost solution to systems designers requiring maximum power in small footprints.

Applications

- Aerospace, Aircraft
- Complex power system
- Portable weaponry
- Distributed Power Architecture
- Electric vehicles

Show actual size:

2.28 x 2.2 x 0.5 in
57.9 x 55.9 x 12.7 mm

Features

- DC input range: 100 – 200V
- Input surge withstand: 225V for 100ms
- Ripple & Noise (20Mhz BW) 300 mv (pk-pk) typical
- DC output: 15V
- Programmable output: 10 to 110%
- Output adjustment +/-10% range
- Regulation: +/- 0.2% no load to full load
- Remote sense compensation
- 1500V, 10MΩ input-to-output isolation
- Output overcurrent and overvoltage protection
- Over Temperature protection
- Input Under voltage protection
- Parallelable, with N+M fault tolerance
- Power density: 100W/Cubic inch
- Parallelable, with N+M fault tolerance
- Efficiency: 93%

Part Number and Selection Information

| Model Part Number | Input | | | Output | | Efficiency 75% Load (%) |
|----------------------|-----------------|-------------|-----------|-----------------|----------------|-------------------------------|
| | Voltage (Volts) | Current (A) | | Voltage (Volts) | Current (Amps) | |
| | Nominal | No load | Full load | (Volts) | (Amps) | |
| E150B15M250B | 150 | 0.030 | 0.962 | 15 | 16.7 | 93 |

Consult factory for other output voltage configurations

Outline Information and Pin-out

| Pin Connection | | Pin Size | |
|----------------|----------|----------|------|
| Pin # | Function | Inch | mm |
| 1 | Vin + | 0.08" | 2.03 |
| 2 | PC | 0.08" | 2.03 |
| 3 | PR | 0.08" | 2.03 |
| 4 | Vin - | 0.08" | 2.03 |
| 5 | Vo - | 0.15" | 3.81 |
| 6 | -S | 0.08" | 2.03 |
| 7 | SC | 0.08" | 2.03 |
| 8 | +S | 0.08" | 2.03 |
| 9 | Vo + | 0.15" | 3.81 |

All dimensions are in inches [mm]

0.08" [2.032mm], 0.15" [3.81mm]

Pin material: Brass

Pin finish: Tin/Lead plated

Baseplate material: Aluminum.

Outline dimension:

2.28"(57.9)x2.2(55.9)x0.5"(12.7)

Max. Weight: 112g

*** Part Numbering:**

E 150 B 15 M 250 B

| 150 | B | 15 | M | 250 | B |
|--------------|----------------------------|-------------|---|----------------|-----------|
| Output Power | A=Maxi B=Mni C=Micro | Input Power | * | Output Voltage | Pin Style |

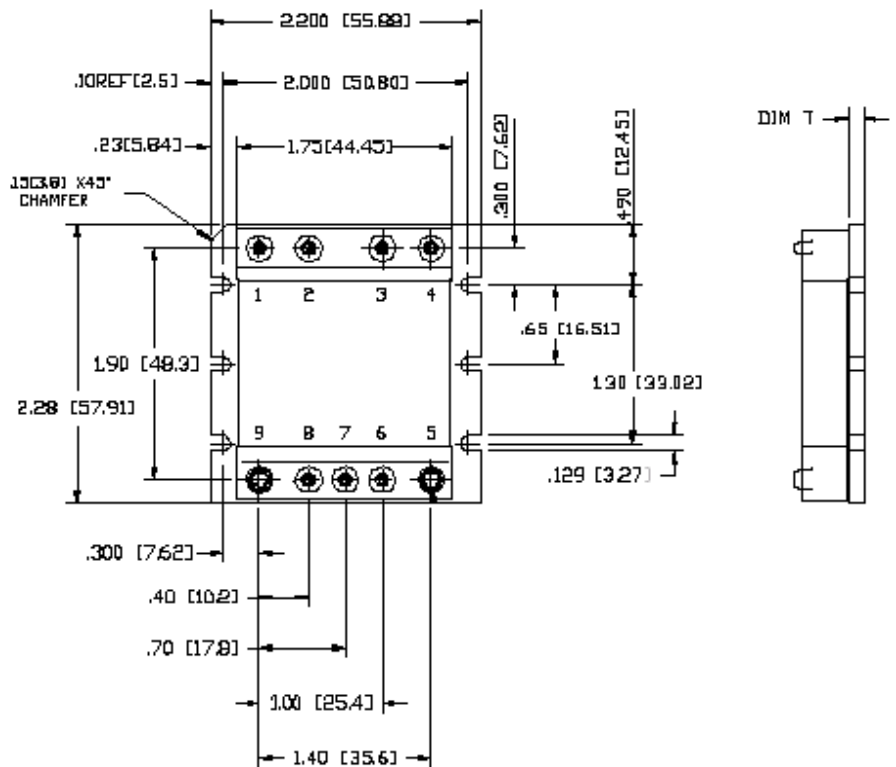

*** Product Grade Temperatures (°C)**

| Grade | Storage | Operating |
|-------|-------------|-------------|
| C | -40 to +125 | -20 to +100 |
| T | -40 to +125 | -40 to +100 |
| H | -55 to +125 | -40 to +100 |
| M | -65 to +125 | -55 to +100 |

Electrical Specification

Typical operating condition at Ta=25°C, Vin=150V unless otherwise noted.

| PARAMETER | NOTES | MIN | TYP | MAX | UNIT |
|--|--|-------|--------------|----------|-------------|
| Absolute maximum rating | | | | | |
| Vin+ to Vin – voltage | | -0.5 | | +150 | Vdc |
| Vin+ to Vin – voltage | <100ms | | 225 | | Vdc |
| PC to –In voltage | | -0.5 | | +7.0 | Vdc |
| PR to –In voltage | | -0.5 | | +7.0 | Vdc |
| +Out to –Out voltage | | -0.5 | | +20 | Vdc |
| +Sense to –Out voltage | | -0.5 | | +20 | Vdc |
| -Sense to –Out voltage | | | 1.0 | | Vdc |
| SC to –Out Voltage | | | -0.5 to +1.5 | | Vdc |
| Isolation voltage (in to out) | | | 3000 | | Vrms |
| Isolation voltage (in to base) | | | 1550 | | Vrms |
| Isolation voltage (out to base) | | | 500 | | Vrms |
| Operating case temperature (M - Grade) | | -55 | | 100 | °C |
| Storage temperature (M – Grade) | | -65 | | 125 | °C |
| Pin soldering temperature | | | 500 (260) | | |
| Ping soldering temperature | | | 750 (390) | | |
| Thermal Resistance and Capacity | | | | | |
| Baseplate to sink; flat' greased surface | | | 0.16 | | °C / Watt |
| Baseplate to sink; thermal pad | | | 0.14 | | °C / Watt |
| Baseplate to ambient | | | 8.0 | | °C / Watt |
| Baseplate to ambient; 1000 LFM | | | 1.9 | | °C / Watt |
| Thermal capacity | | | 83 | | Watt-sec/°C |
| Module Operating Specifications | | | | | |
| Operating input voltage | | 100 | 150 | 200 | Vdc |
| Input surge withstand | <100ms | | | 225 | Vdc |
| Output voltage setpoint | Nominal input; full load; 25 °C | 11.88 | 12 | 12.12 | Vdc |
| Output OVP setpoint | 25 °C;recycle input voltage to restart (1 minute off) | 17.2 | 17.8 | 18.5 | Vdc |
| Output power | At 100°C baseplate temperature | | | 250 | Watts |
| Efficiency | Nominal input; 75% of full load; 25 °C | 91 | 92 | | % |
| Module Input Specification | | | | | |
| Undervoltage turn-on | | | 87.3 | 89.1 | Vdc |
| Undervoltage turn-off | | 73.7 | 76.4 | | Vdc |
| Overvoltage turn-off/on | | | | | Vdc |
| Dissipation, standby | No load | | 5.2 | 6.3 | Watts |
| Module Output Specifications | | | | | |
| Line regulation | Low line to high line; full load | | +/-0.02 | +/-0.2 | % |
| Load regulation | No load to full load; nominal input | | +/-0.05 | +/-0.2 | % |
| Temperature regulation | Over operating temperature range | | +/-0.002 | +/-0.005 | % °C |
| Ripple and noise; p-p | Nominal input; full load; 25°C; 20MHz bandwidth | | 120 | 160 | mV |
| Current limit | Output voltage 95% of nominal | 17 | 19.2 | 21.8 | Amps |
| Short circuit current | Output voltage <250mV | 11.6 | 19.2 | 21.8 | Amps |
| Power sharing accuracy | 10 to 100% of full load | | +/-2 | +/- 5 | % |
| Programming range | Of nominal output voltage. For trimming below 90% of nominal, a minimum load of 10% of maximum | 10 | | 110 | % |

| | | | | | |
|--------------------------------------|---|-----------|---------|-----|----------------|
| | rate power may be required. | | | | |
| Module General Specifications | | | | | |
| Remote sense (total drop) | 0.25V per leg (senses must be closed) | | | 0.5 | Vdc |
| Isolation voltage (in to out) | Complies with reinforced insulation Requirements | 3000 | | | Vrms |
| Isolation voltage (in to base) | Complies with basic insulation requirements | 1550 | | | Vrms |
| Isolation voltage (out to base) | Complies with operational insulation requirements | 500 | | | Vrms |
| Isolation voltage (in to out) | | | 10 | | megohms |
| Weight | | 3.7 (104) | 4 (112) | | ounces (grams) |
| Temperature | | 110 | 115 | | °C |

CONTROL FUNCTIONS – PC PIN

Module Enable/Disable

The module may be disabled by pulling PC below 2.3V with respect to the – Input. This may be done with an open collector transistor, relay, or optocoupler. Multiple converters may be disabled with a single transistor or relay either directly or via “OR’ing” diodes See Figure 1.

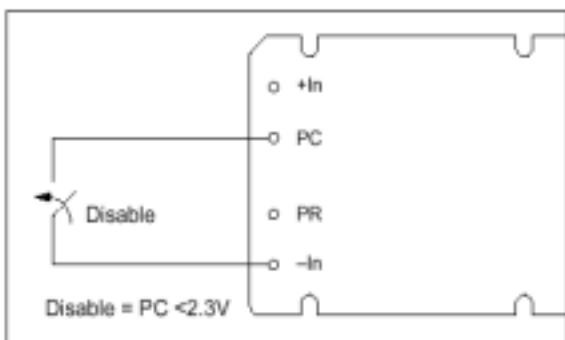

Figure 1—Module enable/disable.

CONTROL FUNCTIONS – SC PIN

Output voltage Programming

The output voltage of the converter can be adjusted or programmed via fixed resistors, potentiometers or voltage DACs. See Figures 2 and 3.

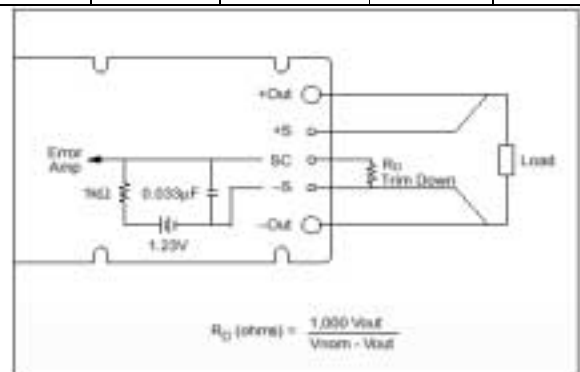

Figure 2 – Output voltage trim down circuit

Trim Down

1. This converter is not a constant power device – it has a constant current limit. Hence, available output power is reduced by the same percentage that output voltage is trimmed down. Do not exceed maximum rated output current.
2. The trim down resistor must be connected to the – Sense pin.

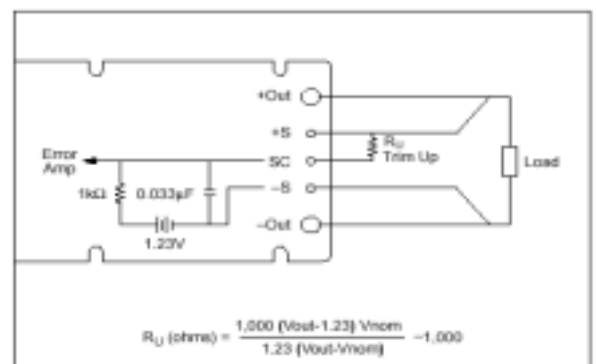

Figure 3 – Output voltage trim up circuit

Trim Up

1. The converter is rated for maximum delivered power. To ensure that maximum rated power is not exceeded, reduce maximum output current by the same percentage increase in output voltage.
2. The trim up resistor must be connected to the +Sense pin.
3. Do not trim the converter above maximum trim range (typically +10%) or the output over voltage protection circuitry may be activated.

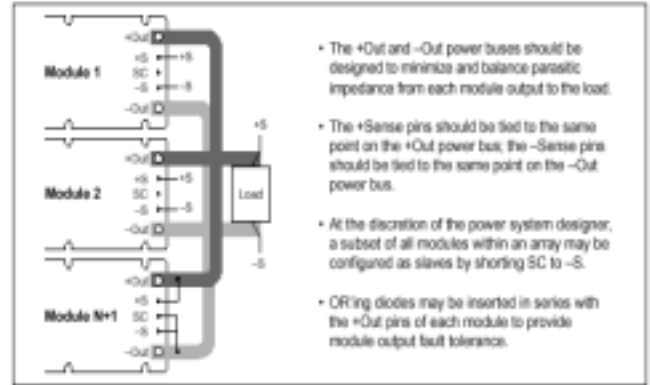

Figure 5 – N+1 module array output connections.

CONTROL FUNCTIONS – PR PIN

Parallel Operation

The PR pin supports paralleling for increased power with N+1 (N+M) redundancy and phased array capability. Modules of the same input voltage, output voltage, and power level will current share if all PR pins are suitably interfaced.

Compatible interface architectures include the following:

DC coupled single-wire interface. All PR pins are directly connected to one another. This interface supports current sharing but is not fault tolerant. Minus In pins must be tied to the same electric potential. See Figure 4.

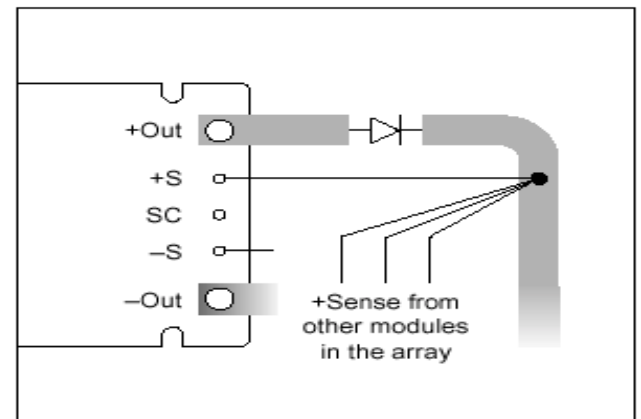

Figure 6 – OR'ing diodes connections.

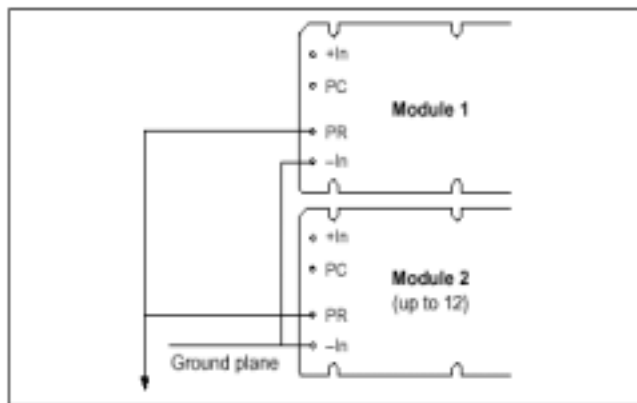

Figure 4 – DC coupled single – wire interface.

Pin Styles

| Designator | Description | Notes |
|------------|----------------|--------------------------------------|
| (None) | Short solder | Requires in-board, mounting |
| L | Long solder | On-Board mounting for 0.065" boards |
| S | Short ModuMate | SurfMate or in-board socket mounting |
| N | Long ModuMate | On-board socket mounting |

Pin Style designator follow the "B" after the output power and precedes the baseplate designator.

Ex. E48B24C250BN – Long ModuMate Pins